

Surname	Centre Number	Candidate Number
First name(s)		0



GCSE

3300U10-1



A19-3300U10-1

MONDAY, 11 NOVEMBER 2019 – AFTERNOON

**MATHEMATICS
UNIT 1: NON-CALCULATOR
FOUNDATION TIER**

1 hour 30 minutes

ADDITIONAL MATERIALS

The use of a calculator is not permitted in this examination.
A ruler, protractor and a pair of compasses may be required.

INSTRUCTIONS TO CANDIDATES

Use black ink or black ball-point pen. Do not use gel pen or correction fluid.

You may use a pencil for graphs and diagrams only.

Write your name, centre number and candidate number in the spaces at the top of this page.

Answer **all** the questions in the spaces provided.

If you run out of space, use the additional page at the back of the booklet. Question numbers must be given for all work written on the additional page.

Take π as 3.14.

INFORMATION FOR CANDIDATES

You should give details of your method of solution when appropriate.

Unless stated, diagrams are not drawn to scale.

Scale drawing solutions will not be acceptable where you are asked to calculate.

The number of marks is given in brackets at the end of each question or part-question.

In question 9, the assessment will take into account the quality of your linguistic and mathematical organisation, communication and accuracy in writing.

For Examiner's use only		
Question	Maximum Mark	Mark Awarded
1.	2	
2.	4	
3.	3	
4.	2	
5.	2	
6.	3	
7.	4	
8.	4	
9.	5	
10.	3	
11.	3	
12.	3	
13.	5	
14.	2	
15.	3	
16.	3	
17.	3	
18.	3	
19.	4	
20.	4	
Total	65	



NOV193300U10101

Formula List - Foundation Tier

Area of trapezium $= \frac{1}{2} (a + b)h$

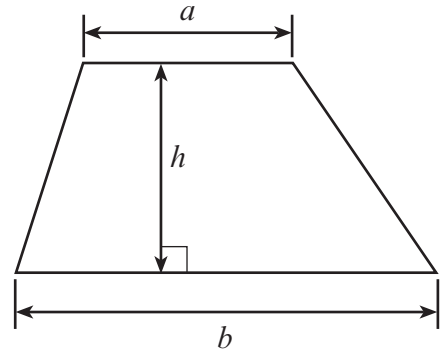

1. (a) On the line below, mark the point B , so that $AB = 7.5$ cm. [1]



- (b) Measure and write down the size of angle x . [1]

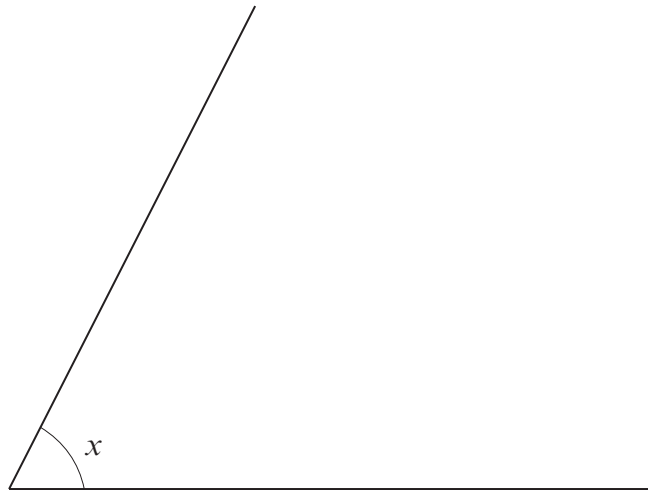

$x = \dots\dots\dots^\circ$



2. (a) Write a number in each box so that each calculation is correct.

(i) $397 + 405 =$ [1]

.....

.....

.....

(ii) $+ 274 = 419$ [1]

.....

.....

.....

(iii) $11 \times$ $= 220$ [1]

.....

.....

.....

(b) Write these numbers in order of size, beginning with the smallest. [1]

6·49

6·94

6·4

6·9

smallest

largest



3. Draw all the lines of symmetry on each of the following shapes.

[3]

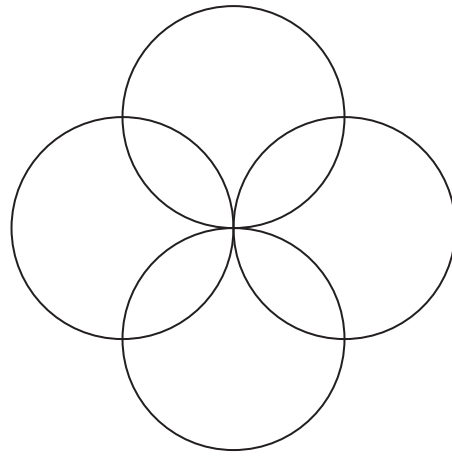
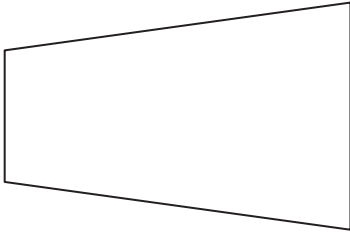

4. Fill in the missing term in each of these number sequences.

(a) 100, 91, , 73, 64

[1]

.....
.....

(b) 4, , 18, 25, 32

[1]

.....
.....



5. (a) Sara has 20 balls in a bag.
There are 15 blue balls and 5 red balls.
Sara chooses a ball at random from her bag.

Describe the chance that Sara chooses a red ball from her bag.
Circle the correct expression from those given below.

[1]

impossible **unlikely** **an even chance** **likely** **certain**

- (b) Gareth has some cards with a number written on each one.
These are Gareth's cards.

125

269

748

731

Gareth chooses one of his cards at random.

Describe the chance that Gareth chooses a card with an odd number on it.
Circle the correct expression from those given below.

[1]

impossible **unlikely** **an even chance** **likely** **certain**



6. (a) Write one of the numbers 3, 5, 7, 9 in each box.
Each number may be used only once.
The sum of the numbers in the column must equal the sum of the numbers in the row.

[1]

	<input style="width: 40px; height: 25px;" type="text"/>	
<input style="width: 40px; height: 25px;" type="text"/>	10	<input style="width: 40px; height: 25px;" type="text"/>
	<input style="width: 40px; height: 25px;" type="text"/>	

Space for working:

.....

.....

.....

- (b) Write a **different multiple of 4** in each box to make this sum correct.

[2]

$$\boxed{} + \boxed{} + \boxed{} = \boxed{40}$$

Space for working:

.....

.....

.....

.....

.....



7. (a) Solve these equations.

(i) $7x = 56$

[1]

.....

.....

.....

(ii) $23 - x = 9$

[1]

.....

.....

.....

- (b) (i) Sian has n boxes.
Each box contains 8 pens.
How many pens does Sian have altogether?

[1]

.....

Number of pens is

- (ii) Meic had m CDs.
He gave 3 CDs to a friend.
How many CDs does Meic have now?

[1]

.....

Number of CDs is



8. Match each expression with its value.

The first one has been done for you.

[4]

50% of 22	→	11
$\frac{1}{5}$ of 90		2
4^2		8
$\sqrt{100}$		10
25% of 80		16
		18
		20
		45
		50

Space for working:

.....

.....

.....

.....

.....



9. *In this question, you will be assessed on the quality of your organisation, communication and accuracy in writing.*

A rod is 4 yards long and another rod is $1\frac{1}{2}$ yards long.

What is the total length of these rods **in inches**?
You must show all your working.

[3 + 2 OCW]

You are given that:

1 yard = 3 feet

1 foot = 12 inches

.....

.....

.....

.....

.....

.....

.....

.....

.....

.....

.....

.....



10.

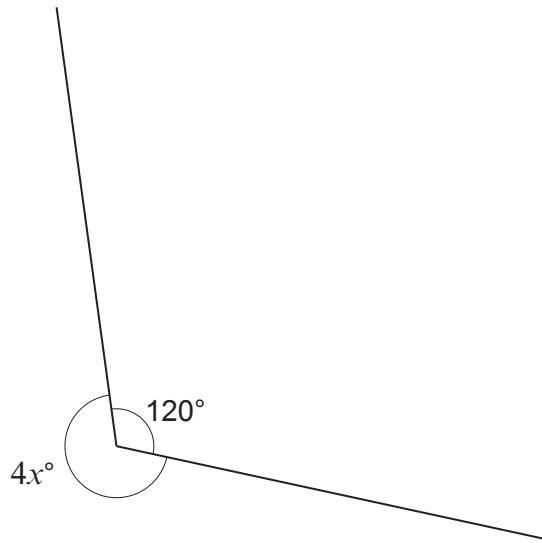

Diagram not drawn to scale

Calculate the value of x .

[3]

.....

.....

.....

.....

.....

.....

$x =$



11. Complete each row of the following table.
The first row has been completed for you.

[3]

Place	Temperature at 10 a.m.	Change	Temperature at 6 p.m.
Cwmbran	2°C	Down 4°C	-2°C
Llanelli	-3°C	Down 1°C	
Llanidloes	-4°C		-1°C
Porthmadog		Up 4°C	3°C

12. Write 7%, $\frac{3}{5}$ and 0.3 in ascending order.

You must show all your working.

[3]

.....

.....

.....

.....

.....

.....

Smallest value → Greatest value



13. (a) Calculate the value of $3x + 4y$ when $x = -6$ and $y = 5$.

[2]

.....

.....

.....

(b) Simplify the expression $9g - 4f - 3g - 5f$.

[2]

.....

.....

(c) Expand $4(3x - 5)$.

[1]

.....

.....



14. The mean of two numbers is 7.
The range of these two numbers is 8.

What are these two numbers?

[2]

.....

.....

.....

.....

.....

.....

The numbers are and

- 15.

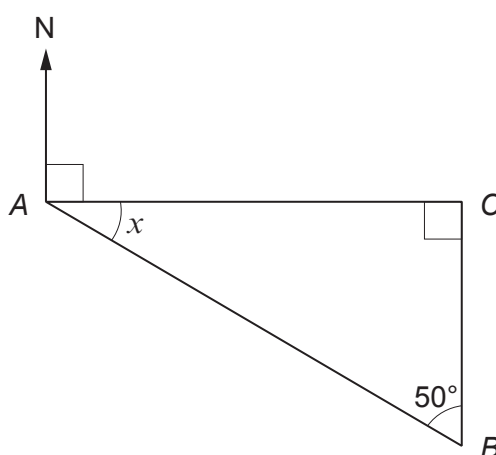

Diagram not drawn to scale

Calculate the size of angle x .
Hence, give the bearing of point B from point A .

[3]

.....

.....

.....

.....

.....

$x =$ $^{\circ}$ Bearing of point B from point $A =$ $^{\circ}$



16. A group of pupils is asked whether they can speak Welsh, French, both languages, or neither language.

Their answers are shown in the Venn diagram below.
The universal set, ϵ , contains all the pupils in the group.

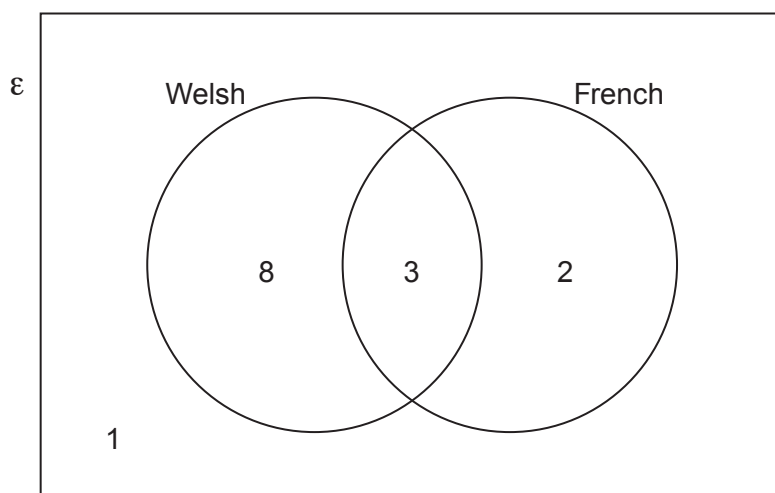

- (a) How many of the pupils cannot speak French? [1]

.....

- (b) One pupil from the group is chosen at random.
What is the probability that this pupil can speak both Welsh and French? [2]

.....

.....

.....



18. (a) What is the total mass when 534 g is added to 3.5 kg?
Circle the correct answer.

[1]

4.034 g

4.034 kg

537.5 g

537.5 kg

884 g

.....

.....

.....

.....

- (b) What is the total length when 35 cm is added to 7.8 m?
Circle the correct answer.

[1]

113 cm

42.8 m

42.8 cm

815 cm

815 m

.....

.....

.....

.....

- (c) How many mm^3 are there in 4 cm^3 ?
Circle the correct answer.

[1]

0.4 mm^3 4 mm^3 40 mm^3 400 mm^3 4000 mm^3

.....

.....

.....

.....



20. 200 young people are taking part in a conference held at Aberystwyth.

(a) One of the young people is chosen at random to be the chairperson.

Complete the table below to find the probability that the person chosen lives outside the United Kingdom (UK). [2]

	North Wales	Mid Wales	South Wales	Elsewhere in the UK	Outside the UK
Probability	0.2	0.3	0.25	0.15	

.....

.....

.....

.....

(b) How many of the 200 young people live in Mid Wales? [2]

.....

.....

.....

.....

.....

.....

.....

.....

.....

END OF PAPER



